

Heathkit of the Month #102:
by Bob Eckweiler, AF6C

Heathkit

ELECTRONIC TEST EQUIPMENT

Heathkit QM-1 'Q'-Meter.

Introduction:

Home-brewing RF circuits often involves the use of inductors (coils, chokes, toroids, RF transformers and such). In many cases you may be required to "wind your own". There are formulas in the ARRL Handbook that help you figure out the number of turns, the diameter, etc. Usually you still end up with a lot of trial and error iterations before the coil performs as needed. Often you will find an inductor in your junk box but not know its value. Many inductors have no markings or only proprietary markings that tell you little if anything.

The Heathkit QM-1 'Q' - Meter:

The QM-1, shown in **Figure 1**, can measure, within the instrument's range:

- The inductance of an unknown coil.
- The 'Q' of a coil (see sidebar).
- The distributed capacity of a coil.
- The capacitance of an unknown capacitor.

It can make these measurements at the frequency the component will be used at, giving more credence to the results.

The QM-1 was first introduced in an ad in the September 1952 issue of *Radio News* for \$39.50. That ad ran for eleven pages and the QM-1 was the first kit featured in the ad. The first page listed "Advantages found only in Heathkits" and announced "Nine New Heathkits This Year". (In those days Heath

Here is a link to the index of Heathkit of the Month (HotM) articles:

http://www.w6ze.org/Heathkit/Heathkit_Index.html



Figure 1: Front View of the Heathkit QM-1 'Q'-Meter. The unit is shown out of its cabinet.

often announced next year's kits in September.) The second ad page led off with the new QM-1. Overall the ad featured 34 kits for sale (excluding probes and adapters). The nine all-new kits for 1953 were:

1. AG-8 Audio Generator Kit ¹
2. AO-1 Audio Oscillator Kit
3. BT-1 Battery Tester Kit

4. DC-1 Condenser Decade Kit #038
5. GD-1 Grid Dip Meter Kit #007
6. **QM-1** "Q" Meter Kit #102
7. RS-1 Resistor Substitution Box Kit #035
8. VC-1 Voltage Calibrator Kit #051
9. VT-1 Vibrator Tester Kit

#nnn signifies the HOtM article that either features or mentions the kit.

PAGE
32

SPECIFICATIONS:

Frequency.....150 Kc—18 Mc on 4 bands.
 Inductance.....1 microhenry to 10 millihenrys.
 Q.....250 Full scale x 1 or x 2.
 Capacitance.....Actual 40 mmf—450 mmf
 Effective 40 mmf—400 mmf
 Vernier ± 3 mmf.
 Tubes.....1—12AT7, 1—6AL5, 1—12AU7, 1—6X5, 1—OD3/VR150.
 Power.....105-125 Volts AC, 50-60 cps, 30 watts.
 Dimensions.....8" high, 17" wide, 6" deep.

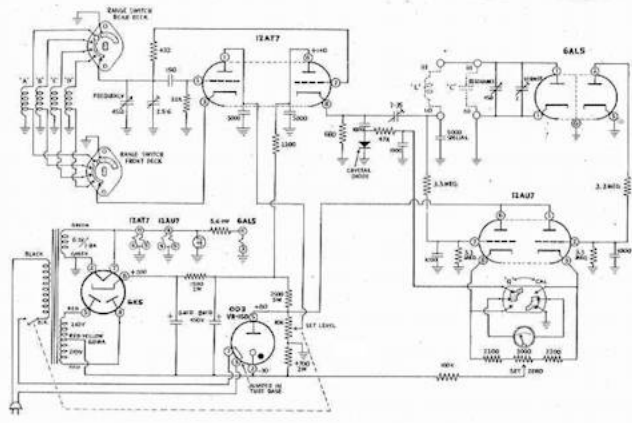

HEATHKIT "Q" meter KIT

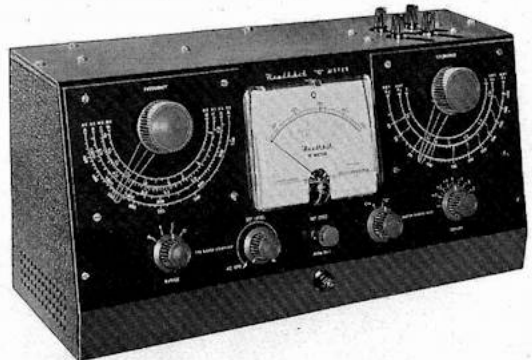

features

- ▶ Variable oscillator permits testing at normal frequencies (150 kc—18 mc).
- ▶ Large 4½" meter mounted in slanted panel for easy reading.
- ▶ Pre-wound RF coils — all sheet metal formed and punched.
- ▶ No special equipment required for calibration — test coil furnished.

\$44.50

MODEL QM-1

SHPG. WT.
14 LBS.

APPLICATIONS — Use Model QM-1 in many service, laboratory and development applications. Check peaking coils, chokes, etc., in radio and TV receivers. Determine the values of unknown condensers both variable and fixed. Compile data for coil winding purposes. Measure RF resistance, distributed capacity and Q of coils.

The Q Meter is not just a "prestige" instrument to be dusted off each morning when opening the shop or lab. It is fully capable of performing many tasks in a matter of minutes that ordinarily require considerable mechanical and mathematical dexterity. Originally a Q meter was out of the financial reach of the average service shop but now Heathkit ingenuity has brought it into line.

Suspected components and parts being developed or manufactured can be tested at frequencies at which they normally are used (150 kc-18 mc). Wide ranges of inductance, capacitance and Q will cover practically all values encountered. All indications are read directly on a large 4½", 50 microampere, panel mounted meter. Surprisingly easy to use, Model QM-1 will take the guess work out of your electronic efforts.

The Heathkit Q Meter uses a 12AT7 oscillator with pre-wound coils to obtain the full frequency range on 4 bands. Oscillator output is metered to provide constant injection. A complete VTVM circuit is used as a resonance indicator, using a 6AL5 twin diode and a 12AU7 VTVM amplifier. Voltage regulated and transformer operated power supply utilize a 6X5 full wave rectifier and an OD3 regulator tube. All other components are of the highest quality in keeping with highest Heathkit standards.

Behind the attractive charcoal gray panel with white lettering is a well laid out and factory-formed chassis. No "extras" are required to build or operate this instrument. A special test coil is provided for calibration purposes. Buy it, build it, use it, and if the Q Meter says so, it's so.

Figure 2: QM-1 ad from the 1956 Heathkit Catalog with schematic and specifications. Note price increase.

The announcement also introduced updated versions of four existing kits:

1. C-3 Condenser Checker Kit
2. O-8 5" Oscilloscope Kit #087
3. T-3 Signal Tracer Kit #009
4. V-6 VTVM Kit #019

The initial delivery of the QM-1 was delayed for a couple of months until Nov. 1952 due apparently to a last-minute design change.

Figure 3 is an image of the QM-1 as shown in the *Radio News* ads of Sept. and Oct. 1952. Note the position of the two large knobs and their associated scales:



Figure 3: Sept. 1952 Image of Early QM-1.

The Nov. 1952 ad shows a redesign of the QM-1 (**Figure 4**). Note that the scales are now below the two large knobs which were moved with their associated variable capacitors upward to just under the binding posts. This was evidently done to shorten critical lead lengths to improve accuracy. While the full reason for the delay was not given, Heath, in their October 1952 flyer commented:

heathkit Q meter kit...

There has been a delay in placing the Q meter in production, but we expect to start deliveries by November 1. It is hard to realize the thousands of hours of engineering time developing a kit of this type consumes.



Figure 4: Nov. 1952 Image of Reworked QM-1.

Hundreds of sets of measurements are made for comparison to correlate with established Q values. Each circuit change necessitated an entire set of measurements. The final version is excellent, however, and well worth waiting for.

In the fall of 1954 the line of Heathkit test equipment underwent a major styling change:

The new instrument panel color combination is high definition white lettering in a soft charcoal panel. Cabinet color is a lighter feather gray.

Chuck Penson WA7ZZE, the author of *Heathkit Test Equipment Products*, calls this style "Classic I". In the introduction to his book² he covers the various styling changes of the Heathkit test equipment line over the lifetime of the company, breaking them down into six styles. If you're into Heathkit test equipment, I highly recommend this book.

Other than a change in style, no circuit or model # changes occurred to the QM-1. As part of the styling changes, new style gray knobs were used. These are the same knobs later used on the DX-20, -35, -40 and -100 as well as many early ham accessories. The QM-1 specifications are given in **Table I**.

Power Requirements:	115 VAC 50/60 cps. 30 watts
Tube complement:	See Table IV
Frequency Range:	150 KC – 18 MC
Inductance Scale Range:	1 μ H – 10 mH
Actual Capacity Scale Range:	40 μ f – 450 μ f
Effective Capacity Scale Range:	40 μ f – 400 μ f
Vernier Capacity Scale Range:	-3 μ f – +3 μ f
"Q" Scale Range:	250 Full scale x1 or x2
Dimensions:	8" H x 17" W x 6" D
Shipping Weight:	14 LBS.

Table I: QM-1 Specifications

The kit continued to be sold for \$44.50 until the mid-1960s when the price increased to \$54.95. It's last appearance in a main yearly catalog was in 1966.

The QM-1 Control Layout:

The QM-1 is built using a cabinet similar to the IB-2 Impedance Bridge with a sloping front panel. Controls and connections on the top, sloping and vertical front panels are listed in **Table II**. The cabinet rear hosts only the exit of the AC line-cord.

USE "L" SCALE WITH GENERATOR SET TO			
7.9 MC	FOR	1-10	micro H.
2.5 MC	FOR	10-100	micro H.
790 KC	FOR	100-1000	micro H.
250 KC	FOR	1-10	milli H.

TABLE III: Table atop QM-1 for measuring "L"

Atop the cabinet are two pairs of black binding posts on one-inch centers. One is marked L for inductance and the other C for capacitance; each has a 'hi' and 'lo' binding post. These are for the component(s) to be measured. They should be directly connected with leads as short as possible (especially

QM-1 Panel Controls and Connections:

Front Sloping Panel, Top Row (left-to-right):

FREQUENCY: 450 μ f var. capacitor with vernier dial (6:1) and four frequency scales:

- A:** 150 – 450 kc
- B:** 450 – 1,500 kc
- C:** 1.5 – 5 mc
- D:** 5.0 – 18 mc

Meter 4.5" 50 μ A with two scales:

Q 0 – 250 (no units)

MULTIPLY Q BY X1, X2: (These are level set-lines on meter used for calibration ^a)

RESONANCE: 450 μ f var. capacitor with vernier dial (6:1) and three scales:

- C_T** 450 – 40 μ f
- C_E** 425 – 40 μ f
- L** 1 – 10 (X1, X10, X100 μ H, X1 mH ^b)

Front Sloping Panel, Bottom Row (left-to-right):

RANGE: 2 pole, 4 position Rotary switch:
A, B, C, D.

SET LEVEL: 3 K Ω pot w/switch at CCW position.
AC OFF full (CCW).
no scale, arrow around control.

SET ZERO: 10 K Ω pot, no markings.

Meter: 2-pole 2-position rotary switch:
CAL, "Q"

VERNER: 7 μ f variable capacitor.
+ 3 +2 +1 0 -1 -2 -3
with 1/2 μ f tic marks.

Top Panel: (4 binding posts above RESONANCE knob.)

- L** (hi) left-front
(lo) left-rear
- C** (hi) right-front
(lo) right-rear (ground)

Front Vertical Panel, centered

pilot light

Notes:

- a. Marked in **RED** on the meter face
- b. Depends on frequency setting. See text).

Table II

with inductors). A table on the left side of the top gives settings for measuring inductance. **Table III** is a reproduction.

QM-1 Construction:

The QM-1 came out early in the long history of the development of the soon to be famous Heathkit manual. In the early QM-1 manual dated 11/5/1952 only one page of the manual (page 3) covers construction of the kit. Construction is supported by three pages of drawings with copious notes in the drawings. These drawings, along with the schematic, also came in a large pictorial size to tape above the work area. There is no step-by-step assembly procedure to guide you. A lot is left to the builder to understand. For instance six sets of #3-48 hardware (screw, lock washer and nut) are provided, but nowhere are you told where to use them. (They mount the three miniature tube sockets, and are probably the only hardware that would fit.) On that single page of construction Heath recommends: *Assemble the generator sub-chassis, the "Q" sub-chassis, the main chassis and the panel separately. Wire the first three parts as far as possible, then mount both sub-chassis on the main chassis and complete the wiring between these parts. Attach the panel*

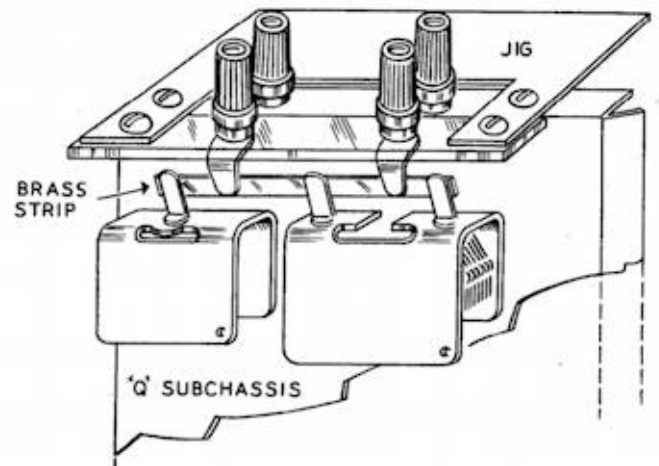

Figure 6: Manual drawing (circa 1960) showing low inductance connection between capacitors and Binding posts. Note use of a jig to align the brass strip.

to the chassis and complete the wiring. That is one of the three paragraphs on page 3 covering construction. The page also has two construction notes and a few diagrams, such as one showing the tube socket numbering. A later, 9/18/1964, manual still did not give step-by-step instructions, though manuals with that feature were being provided with all the newer kits. It appears there never was a Q-1 manual with step-by-step assembly instructions.

A critical part of construction is the connections to the **RESONANCE** and **VERNIER** variable capacitors. To keep leads as short as possible

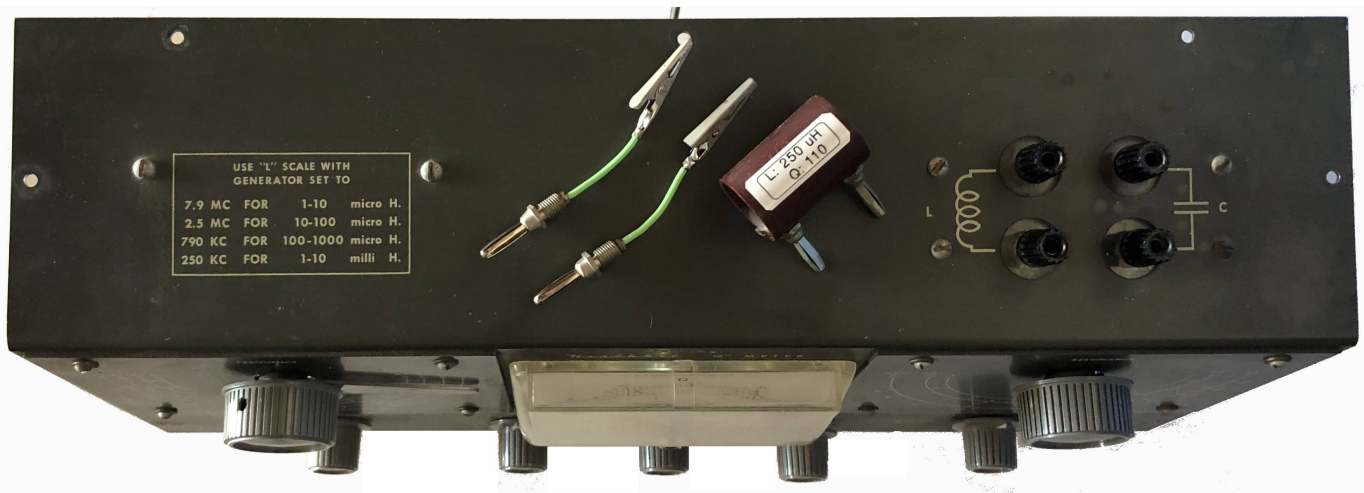

Figure 5: Top View of the Heathkit QM-1 'Q'-Meter. Sitting on top is the Heath supplied test coil used for calibration and a pair of homemade test leads. The unit is shown out of its cabinet.

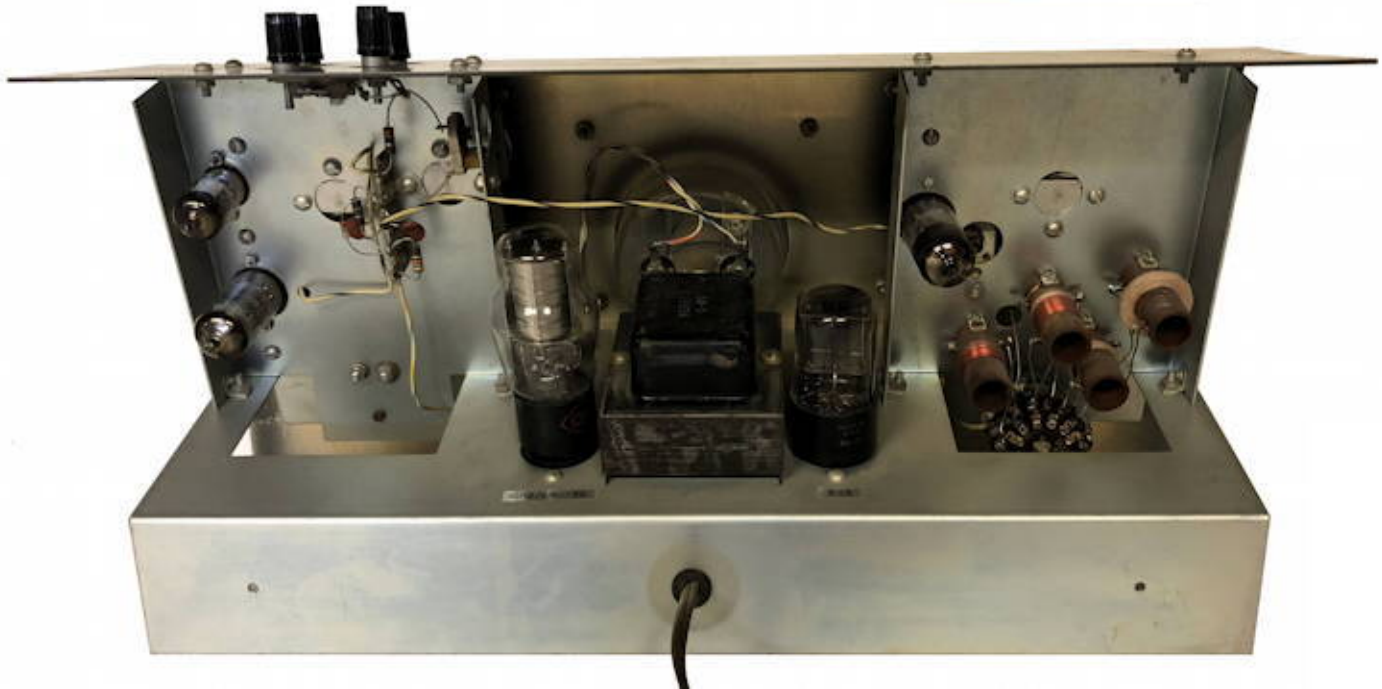

Figure 7: Rear view of the QM-1 chassis. On the left is the resonance sub-chassis; on the right is the RF generator sub-chassis. the power supply, and meter are located between the sub-chassis.

sible Heath moved these capacitors to a point where they could be connected to the binding posts using a straight low-inductance brass strip. Early on, the physical alignment of these components was done using the panel temporarily fastened inverted to the 'Q' sub-chassis to act as a template. Later on, Heath supplied a metal jig to provide better alignment (see **Figure 6**). Pulleys and dial cord allow the VERNIER capacitor to be placed closely alongside the RESONANCE capacitor and still have its control knob located below.

QM-1 Calibration:

Checkout and calibration of the QM-1 is covered on page 4 of the 16 page manual. The QM-1 comes with a test coil (Heath part #: 40-23). If you decide to purchase a QM-1 be sure this part is included. Store it plugged into the 'L' binding post terminals when not in use so you don't lose it. Marked on the test coil is its inductance, equivalent capacitance and Q. On mine they were scratched into the cover and hard to read after all these years,

so a label was added. The test coil provided was marked with an inductance of 250 μ H, a 'Q' of 110, and a CE of 96 μ f³. This coil is used for calibration. This one measured very close to specification in a qualified cal lab.

Calibration is done in two stages. First the RF generator section is calibrated by setting it to zero beat with a known broadcast signal in the 1200 through 1500 kc range on band

QM -1 Tube / Diode Line-up

<u>No.</u>	<u>Tube</u>	<u>Type</u>	<u>Function</u>
V1A	½-12AT7	Triode	RF Oscillator
V1B	½-12AT7	Triode	Buffer-Follower
V2A	½-6AL5	Diode	'Q' Rectifier
V2B	½-6AL5	Diode	Balance Rectifier
V3A	½-12AU7	Triode	VTVM (Differential
V3B	½-12AU7	Triode	Amplifier)
V4	0D3/VR150	Gas-VR	150 V Regulator
V5	6X5	Dual Diode	Full-wave Rectifier
D1	HD2257	Ge Diode	Crystal Signal Rectifier

Table IV: QM -1 Tube / Diode Line-up

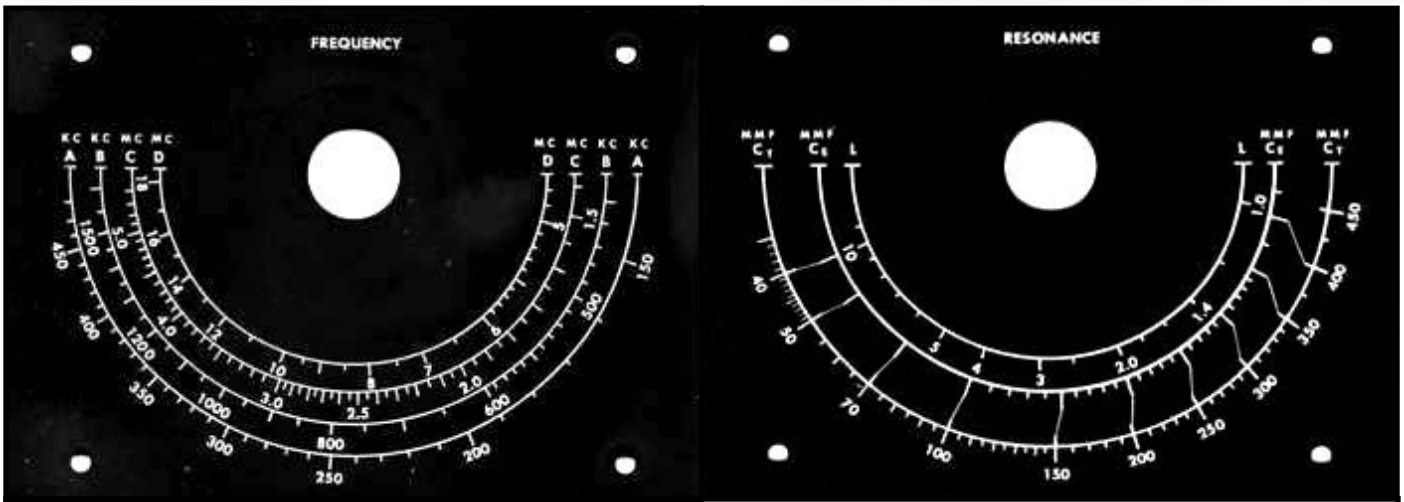

Figure 8: On the left is the FREQUENCY dial showing the four bands. On the right is the RESONANCE dial showing the three scales, Inductance 'L', CE - Capacitance (equivalent) and CT - Capacitance (actual). CE is used to determine the distributed capacitance of an inductor; it is the capacitance of the RESONANCE capacitor in series with the 5000 µpf padder capacitor and corrected for stray capacitance.

B. This is done using trimmer C2 located on the generator sub-chassis. Heath states that this should result in the calibration being within 3% on all four bands. If you have a general coverage receiver that has a crystal calibrator (or better) you may easily check the accuracy on the other bands.

To calibrate the 'Q' section, first be sure the meter mechanical zero is properly set with the power off. Then set the generator frequency to 1000 kc and, with the test coil plugged into the 'L' terminals, switch the CAL-'Q' meter switch to **CAL**. With the **SET LEVEL** control at minimum, the meter should read zero. Now advance the SET LEVEL control until the meter is over the red **X1** mark. Move the CAL-'Q' meter switch to 'Q'; adjust the **SET ZERO** control until the meter is on zero. Next adjust the **RESONANCE** control for maximum meter deflection; then adjust trimmer (C8) till the meter reads the 'Q' indicated on the test coil. Finally, loosen the pointer on the **RESONANCE** control and move it on its shaft until the pointer is over the CE value given on the test coil. Be sure to use the middle CE scale.

The QM-1 Circuit:

Figure 11 is a schematic of the QM-1, and **Table III** shows the tube line-up. The QM-1 can be broken down into three sections, the power supply, the RF generator sub-assembly and the resonance sub-assembly which includes the VTVM circuit.

The Power Supply:

The power supply is transformer based. The 420 VCT 60 mA HV secondary winding is full-wave rectified by V5 and filtered by C14A, R14 and C14B to produce about 210 volts DC relative to the HV secondary center-tap. The 6.3 Vac., 2.8 A filament secondary winding lights four tube heaters plus the pilot lamp. A 5.6 Ω 1-watt resistor⁴ (R16) in series with the 6AL5 rectifier tube drops its filament voltage down to under 5 Vac. Running the 6AL5 at a lower filament voltage lowers the cathode contact potential and improves small signal linearity.

An OD3 (VR150) voltage regulator tube regulates a voltage source to 150 Vdc. Since the HV secondary center tap is connected to ground via R17, which makes up a voltage divider with the overall circuit resistance,

the center tap is at -70 Vdc, and since it is connected to the cathode of the VR tube the anode of the VR tube is at $+80$ Vdc. This negative voltage is used for the VTVM circuit. Thus the power supply has three outputs, referenced to ground: $+140$ Vdc, $+80$ Vdc and -70 Vdc.

The OD3 VR150 tube has a jumper between pins 3 and 7. This jumper is there to disable a circuit should the tube not be in place. This jumper is used by Heathkit likely to prevent meter damage should the VR tube be removed and power applied. Heath actually wired the AC primary to the transformer through the jumper so the power could not be turned on⁵ without the tube in place.

The RF Generator:

V1A, $\frac{1}{2}$ -12AT7 triode is wired as a Hartley oscillator. The frequency range is determined by one of four coils that is switched into the circuit by the **RANGE** switch. That coil, the 450 μf vernier-driven **FREQUENCY** control C1, and a parallel calibration trimmer C2, determine the frequency. The SET LEVEL control (R3) adjusts the plate voltage of V1A setting the RF level.

V1B, $\frac{1}{2}$ -12AT7 triode is a cathode follower isolating the load from the oscillator section. Low impedance RF voltage appears across R5 and is fed to the resonance section.

A sample of the RF voltage is coupled through C7, rectified by the crystal diode D1, filtered by R6 and C6 and, with the CAL-'Q' meter switch in CAL, the RF voltage is read on the meter.

The Resonance Circuit & VTVM:

To measure 'Q', a coil is resonated with a capacitance at a frequency set on the RF generator. The capacitance is the sum of the RESONANCE capacitor, its VERNIER capaci-

tor and any additional capacitance that may be added across the 'C' terminals (along with any stray capacitance).

The inductor is placed across the 'L' terminals. C9 is a special, very low-inductance inductor padder capacitor, that is also in the circuit, effectively in series with the resonance capacitance. Due to its large size (5000 μf) compared to the resonance capacitance, C9 has little effect on resonance. A small value trimmer capacitor, C8 injects RF into the circuit. Due to its small value, and due to



Figure 9: Side view of Resonance sub-chassis.

the RF voltage being set to a fixed level on the meter, it produces a nearly constant injection current. This trimmer is adjusted to calibrate the 'Q' section of the instrument.

The RF voltage appearing across the coil is practically the same voltage that appears across the capacitor due to the large size of

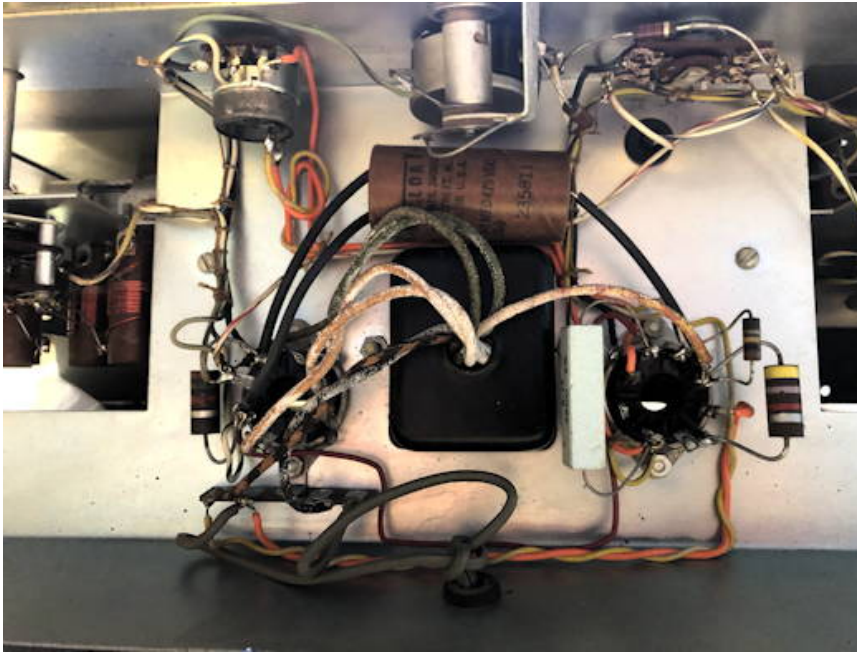

Figure 10: Bottom view of main chassis The 6X5 rectifier is the right octal socket and the VR tube socket is on the right.

C9. This voltage is rectified by V2A and is fed to the the VTVM differential amplifier.

The more efficient the resonant circuit is, the higher the voltage across the coil will be. Losses will result in lower voltage. With the input signal calibrated, the VTVM will record the 'Q' of the circuit. Since the coil usually has the highest losses by a significant amount the circuit Q can be assumed to be the Q of the coil. There are exceptions to this, such as the use of very high Q coils with low capacity settings which are discussed in the manual.

The assumption that the resonance capacitance is small compared to the injector padder, C9, is not true under all situations. Should a large capacitance be used across the C terminals it needs to be taken into account; this also is discussed in the manual.

The VTVM part of the instrument consists of a differential amplifier made up of triodes V3A and V3B. Their cathodes are tied together

er after the SET ZERO circuit which in turn is connected to a constant current source of about 700 μA set by R18 and the minus 70 volt source. If no input is present an identical current of about 350 μA flows in each leg of the amplifier Any circuit imbalance due to component tolerances may be corrected by the SET ZERO control. When the CAL-'Q' meter switch is set to 'Q', the 50 μA meter is connected between the cathodes of V3.

When a negative voltage is applied to the grid of V3A its cathode current is reduced forcing V3B current to rise. This causes a difference in cathode voltages causing the meter to move upscale in relation to the voltage applied to the grid. The grid of V3B is connected to a circuit identical to the grid of V3A except for the resonance circuit input. V2B helps balance out any contact potential errors created by V2A.

QM-1 Operation:

It is highly suggested that one purchase or download the manual before attempting to make measurements with the QM-1. There are formulas and calculations that need to be made for some of the measurements; none are really difficult. The manual includes step-by-step instructions for making the measurements noted in the section following the introduction. **The CAL-'Q' meter switch should be placed in the CAL position whenever connecting a coil or capacitor to the binding posts.**

Measuring Inductance:

To measure the inductance of an unknown coil use the table printed atop the QM-1 (reproduced in this article as Table II). Start by

setting the RF generator to one of the four frequencies using an approximation of which of the four decade ranges the coil inductance is in. Connect the coil and adjust the RESONANCE control for the maximum reading. Read the inductance on the L scale using the correct power of ten multiplier given in the table. If no peak is found try a different frequency range.

Measuring the "Q" of a coil:

Connect the coil to be measured between the two L binding posts. In the generator section, set the generator to the desired frequency. Turn the CAL-'Q' meter switch to CAL, and with the SET LEVEL control at minimum, zero the meter with the SET ZERO control. Now, adjust the SET LEVEL control until the meter is over the red X1 mark. Move the CAL-'Q' meter switch to 'Q' and adjust the RESONANCE control for the maximum meter reading. Read 'Q' on the meter. If the meter reads off scale, repeat using the X2 instead of X1 mark, and be sure to multiply the 'Q' meter reading by two.

Measuring Distributed Capacitance of a Coil:

Connect the coil to be measured between the two L binding posts. Set the RESONANCE control to a small convenient value; the manual recommends 100 μf on the CE scale. Record this value as C_A . Set the CAL-'Q' meter switch to 'Q' and adjust the generator section for maximum meter reading. Now change the generator to one-half the frequency it was at to achieve the maximum meter reading. Adjust the RESONANCE control to give maximum indication on the meter.. Note the new capacitance on the CE scale, and record this value as C_B . The distributed capacitance (C_D) may be obtained from the formula:

$$C_D = \frac{C_B - 4C_A}{3}$$

WHAT IS 'Q'?

Certain passive electronic components such as capacitors and inductors store energy. These devices have a 'Q' or quality factor associated with them. 'Q', which has no units (Ω/Ω), measures the efficiency at a given frequency. 'Q' is defined as the reactance X at a given frequency divided by the effective resistance R. Since Xc is negative the absolute value is used.

$$Q = \left| \frac{X}{R} \right|$$

The effective resistance is made up of everything in the component that contributes to energy loss. Capacitors generally have high 'Q' values at frequencies in the HF range and can be ignored. Not so with inductors; while wire resistance plays a major role, so does skin-effect at higher frequencies as well as core losses. Skin effect is the loss of cross-sectional area of the wire due to the tendency of RF to travel closer to the surface of the wire as the frequency increases, raising the RF resistance. Core losses are losses developed in any core material used to increase inductance (ferrite, powdered iron, brass, etc.)

The manual comments: *Note: While this method is not completely accurate, it will suffice in most cases. The accuracy may be increased by repeating the measurement with different values of CA and averaging the results.*

Measuring Capacitance:

Instructions are also given in the manual for two ways to measure capacitance. One is for capacitors below 425 μf and down to less than 1 μf . And the other is a rather complex procedure for capacitors above 425 μf , up to a few thousand μf . This second procedure is available in the manual and will not be covered. Suffice it to say it would be a lot easier to measure the capacitance on a capacitor checker such as the Heathkit IT-11 or IT-28.

Capacitances Below 425 μf :

Connect a test coil between the two L binding posts. Connect the capacitor to be measured between the two C binding posts. Set the RESONANCE control to a small convenient value; the manual recommends 40 μf on the

C_T scale. Record this value as C_A. With the meter switch at 'Q', adjust the generator section for maximum reading on the meter. Remove the unknown capacitor and readjust the RESONANCE control for maximum indication on the meter. Record this value as C_B. Calculate C_X, the unknown capacitor, using the formula:

$$C_X = C_B - C_A$$

For small capacitances, less than 3.5 μf, use the VERNIER control and read it directly.

Summary:

The QM-1 shown in the photos is currently undergoing restoration. Parts are on order including two 10 μf electrolytic capacitors to replace the dual 8 μf 475 V filter capacitor C14, as well as new resistors to replace R14 through R17 in the power supply section which measured out of tolerance. A few other out of tolerance resistors are also slated for replacement throughout the unit.

The major problem encountered with this QM-1 is the vernier drive on the FREQUENCY and RESONANCE controls. Each variable capacitor has the drive built-in to it. Their lubricant dries out after decades, and the concentric shafts stick together destroying the vernier effect.

When the QM-1 was first obtained both verniers were frozen. With A LOT of work they were freed up, but the fix only lasted a few years. This time they were cleaned up and the old hardened grease was removed and replaced with new white lithium grease. Hopefully they should continue to function for a decade or two. When the QM-1 is restored and functioning, a restoration article will likely be written, and it will include the technique used to free up and re-lubricate the vernier drives.

Notes:

1. The AG-8 was preceded by the AG-7 which was a sine-square wave generator which was a different instrument than the new AG-8. No AG-1 through AG-6 existed. Heath had earlier G-1 to G-5 kits that were generators of various types (RF, audio, sweep) and decided to give them each their own product prefix AG for audio, SG for RF and TS for TV sweep.
2. **Heathkit Test Equipment Products** by Chuck Penson - WA7ZZE. ISBN 2014, 978-0-615-99133-7, available from amazon.com.
3. All the Heath test coils (40-23) provided with the QM-1 found so far appear to have these same parameters.
4. R16, a 5.6 Ω 1-watt resistor in series with the 6AL5 heater should be checked and replaced, as it has probably increase significantly in resistance since new.
5. Use caution around the V4 tube socket. When plugged in, even though the power switch is off, there may be AC line voltage present.

Don't Forget to Vote:

Election day is fast approaching. It is amazing that so many people don't exercise their right to vote. In some states, even for a presidential election, the turnout is significantly below 50%. As the saying goes, **Use it or lose it**. And folks, we are closer than ever to losing it. Choose your candidate carefully; remember it's your choice alone, and then cast your ballot on or by election day. You must be a US citizen and you must be registered.

73, from AF6C



This article originally appeared in the September 2020 issue of "RF", the newsletter of the Orange County Amateur Radio Club - W6ZE.

Thanks - AF6C

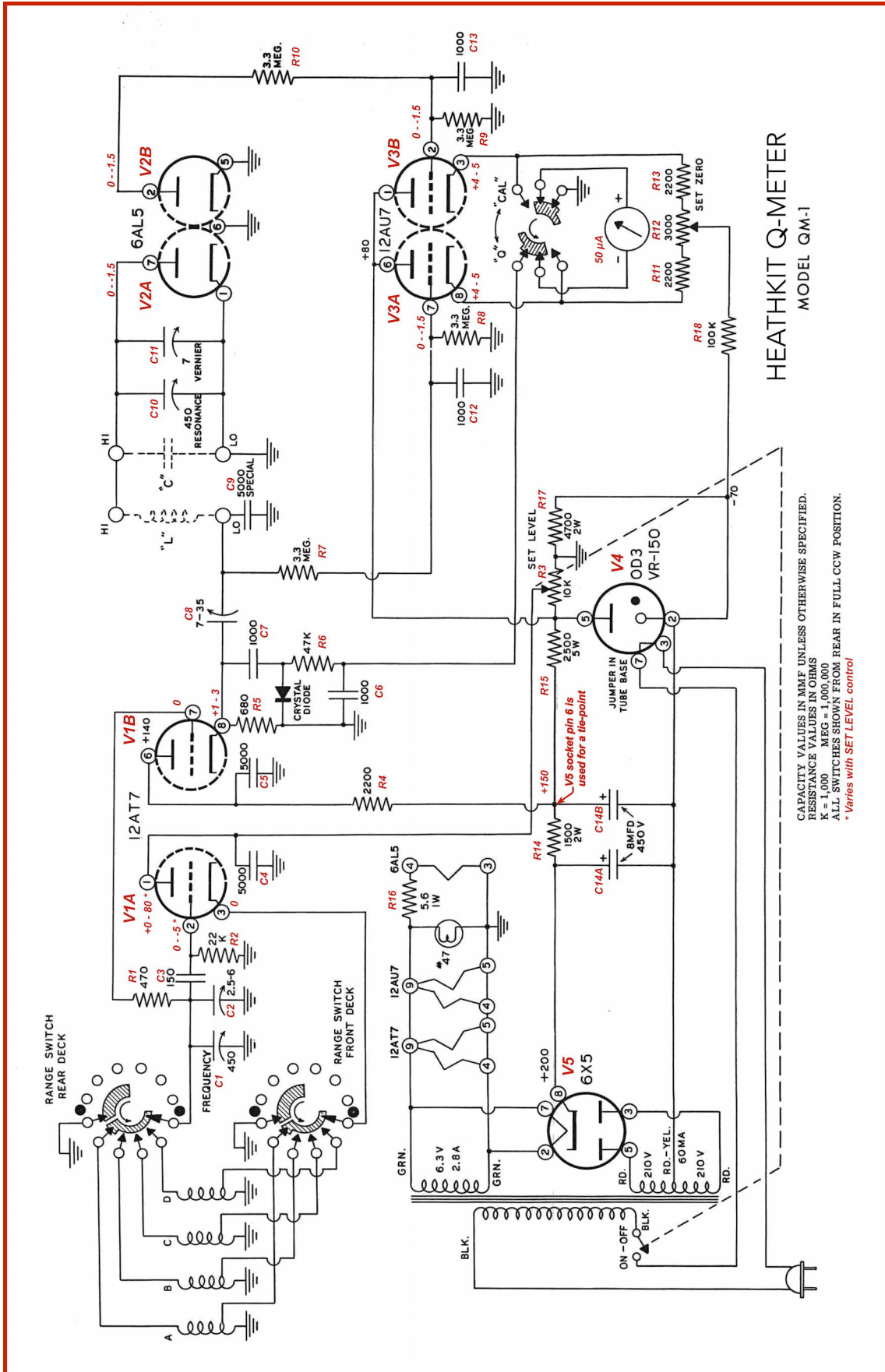

REVISION NOTES:

A:

The third paragraph under QM-1 Calibration:

Was:

To calibrate the 'Q' section, first be sure the meter mechanical zero is properly set with the power off. Then set the generator frequency to 1000 kc and, with the test coil plugged into the 'L' terminals, switch the CAL-'Q' meter switch to **CAL** and, with the **SET LEVEL** control at minimum, adjust the **SET ZERO** control until the meter is on zero. Now advance the SET LEVEL control until the meter is over the red **X1** mark. Move the CAL-'Q' meter switch to '**Q**'; adjust the RESONANCE control for maximum meter deflection; then adjust trimmer (C8) till the meter reads the 'Q' indicated on the test coil. Finally, loosen the pointer on the RESONANCE control and move it on its shaft until the pointer is over the CE value given on the test coil. Be sure to use the middle CE scale.

Is:

To calibrate the 'Q' section, first be sure the meter mechanical zero is properly set with the power off. Then set the generator frequency to 1000 kc and, with the test coil plugged into the 'L' terminals, switch the CAL-'Q' meter switch to **CAL**. **With the SET LEVEL control at minimum, the meter should read zero. Now advance the SET LEVEL control until the meter is over the red X1 mark.** Move the CAL-'Q' meter switch to '**Q**'; **adjust the SET ZERO control until the meter is on zero. Next** adjust the RESONANCE control for maximum meter deflection; then adjust trimmer (C8) till the meter reads the 'Q' indicated on the test coil. Finally, loosen the pointer on the RESONANCE control and move it on its shaft until the pointer is over the CE value given on the test coil. Be sure to use the middle CE scale.

During editing a sentence got pasted into the wrong place and was missed.

(Thanks to Brian Breczinski for catching the error in May of last year.)

The caption for Figure 10:

Was:

... and the VR tube socket is on the right.

Is:

... and the VR tube socket is on the **left**.